

HTA23

Series
Actuator

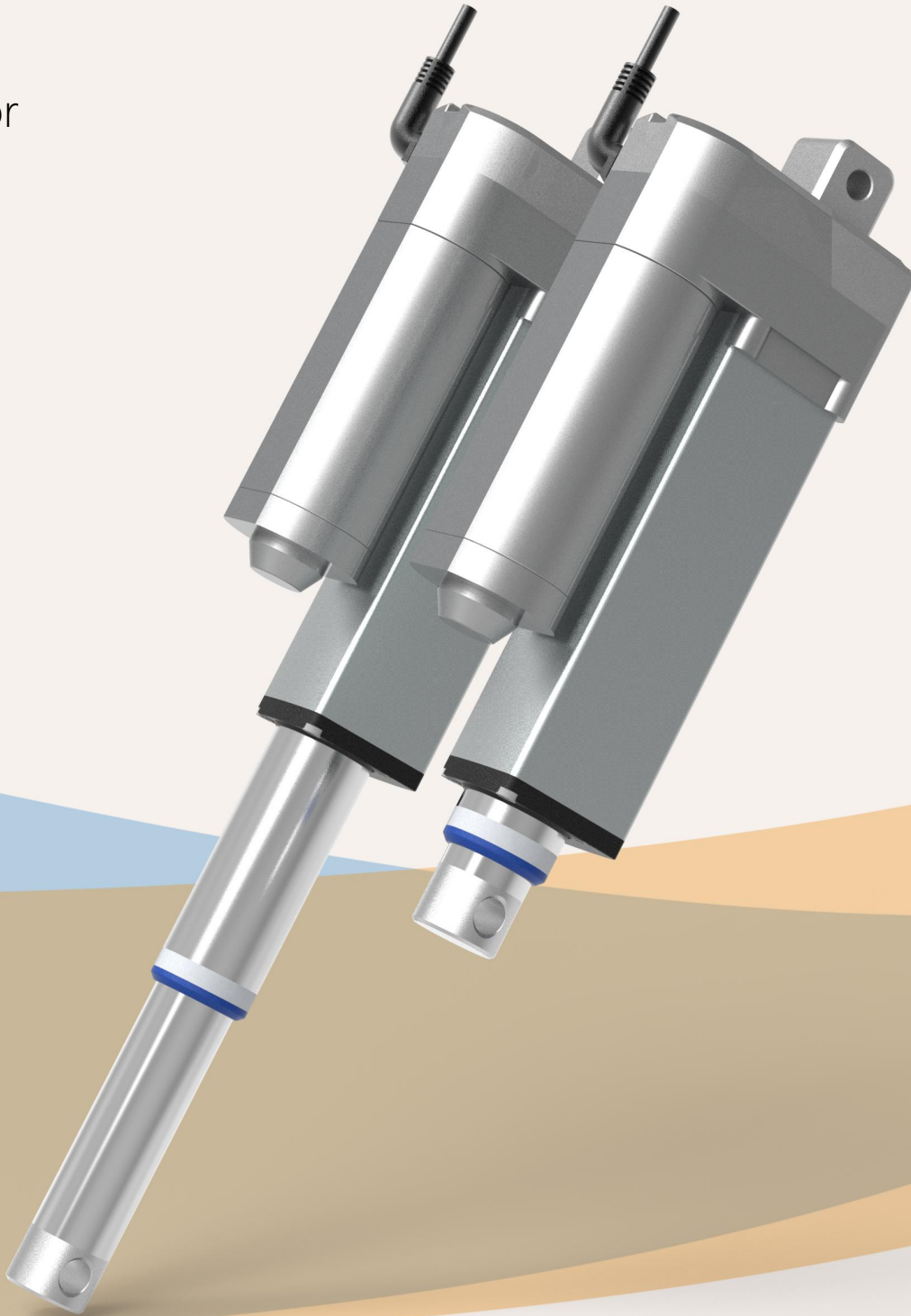

HTA23

Series Actuator

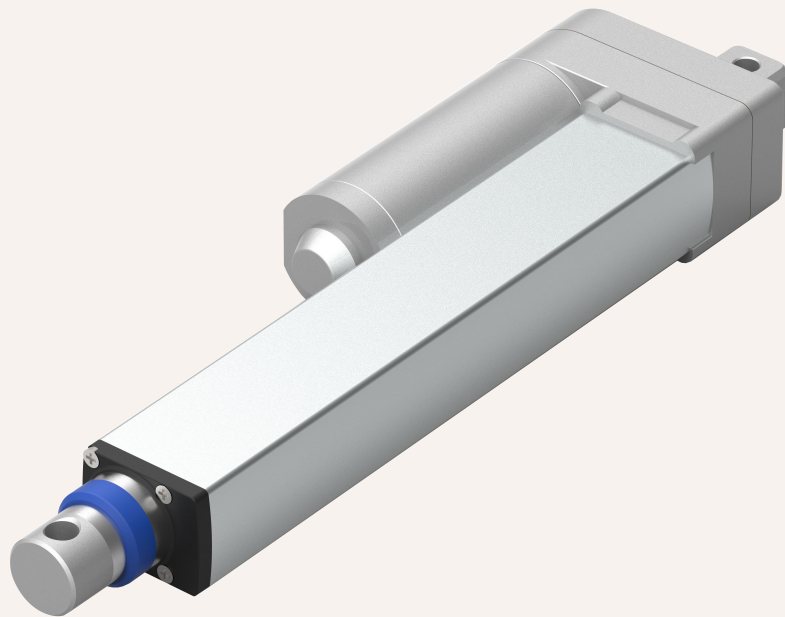

Product categories

1. Furniture applications
2. Medical applications
3. Industrial applications
4. Automotive applications
5. Security applications

HTA23 multi-stage linear actuator is one of the most distinctive electric actuator products developed by GeMinG. This product is widely used in various fields, such as production lines, medical, smart home, military, textile and other industries. Multi-stage linear actuator has the functional characteristics of precise drive and control, stroke adjustment, complex action realization, wide application, customized service and high quality assurance.

Functional Overview

Operating voltage:	12V DC or 24V DC or 36V or 48V DC
Maximum thrust:	2,500N (thrust only)
Speed at full load:	10.mm / s (load 2,500N)
Minimum installation size:	Stroke / 2+ 165mm Stroke / 2+ 185mm (stroke >1000 MM)
Dynamic lateral torque:	30Nm
Static lateral torque:	50Nm
Color:	Ivory or black
Voice:	52DB
Safety certification:	Comply with ISO9001-2008,
Operating temperature range:	-25 ° C ~ + 70 ° C
Full performance temperature range:	+5 ° C ~ + 45 ° C
Protection level:	IP65
Screw selection:	Trapezoidal screw
Other options:	Hall sensor, active signal, passive signal
Control options:	Synchronous control (synchronous error-free), independent control, CAN bus
CE and RoHS compliant, compact size Suitable for small space applications	High-strength metal zinc alloy gearbox and housing, Built-in limit switch (but not adjustable)

Smart Drive

As people live in a comfortable environment, the quality of life that people value is constantly improving. However, designers are increasingly demanding smart home designs that require components that can communicate and operate with each other without manual interaction. GeMinG is meeting this demand and helping to usher in new possibilities.

One of GeMinG's products, the actuator, must be what you need.

Please visit www.Gemingag.com

Drawings

Standard size
MM

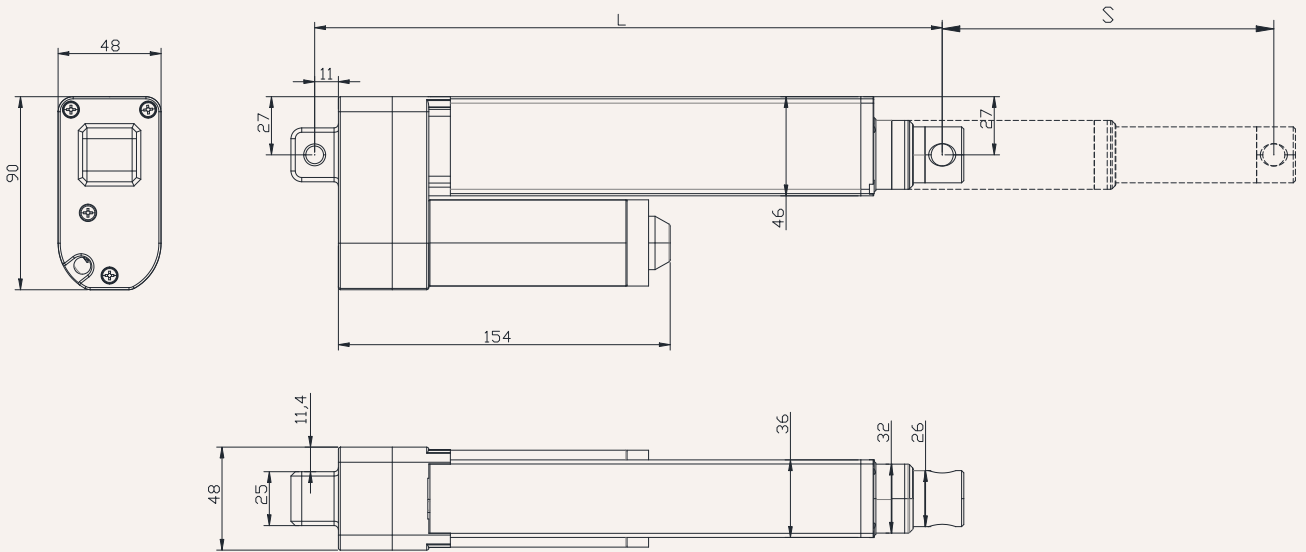

S: Stroke

L: Retracted length

L = Stroke / 2 + 165mm

Stroke greater than 1000MM, installation size L = Stroke / 2 + 185MM

Installation angle (counterclockwise):

0 = 0 Degrees

9 = 90 Degrees

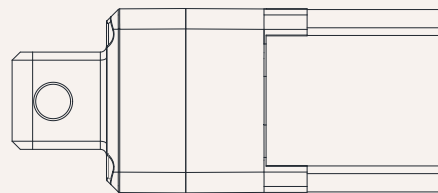
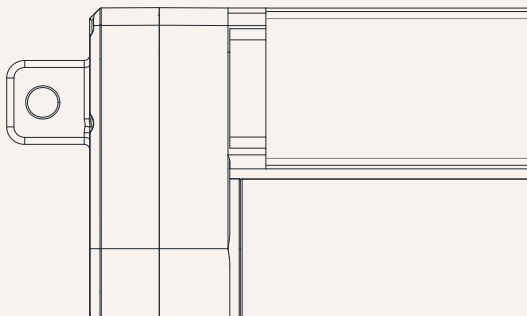

Drawings
Standard size
MM

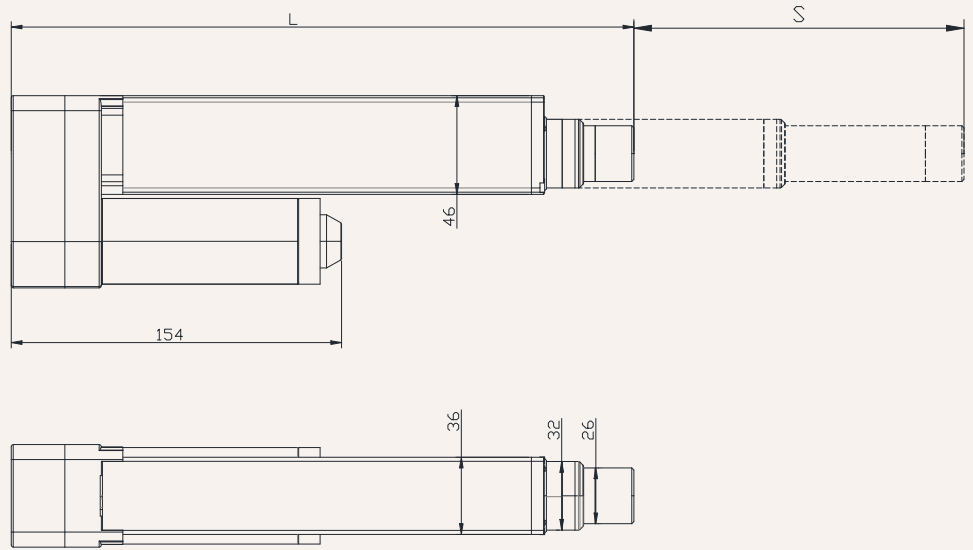
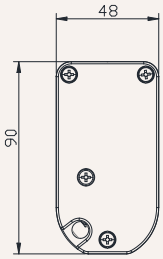

S: Stroke

L: Retracted length

L = Stroke / 2 + 145mm

Stroke greater than 1000MM, installation size L = Stroke / 2 + 165MM

load and speed

Code	Rated load Thrust N	Pull N	Self-locking force static conditions static N	Rated load current A	Output speed no load 24V DC mm/s	Rated load 24V DC mm/s
Motor voltage (24V DC)						
A	2,700	2,700	3,000	4.1	9.0	7.2
B	2,000	2,000	2,000	4.1	18	14
C	1,500	1,500	2,000	4.1	25	20
D	1,100	1,100	1,500	4.0	36	29
E	600	600	600	4.1	72	58

Notes

1. The speed and current on the left are the data of extension under thrust.
2. When the motor is 12V, the speed is about the same, and the current is about 2 times higher.
3. The current & speed in the table are the average test values of the extension direction under thrust application.
4. The current & speed in the table and the curve are the average test values of the control box (GeMinG), and there is an error of about 10% depending on the model of the control box.
(The voltage is about 29V DC when unloaded, and it drops to about 24V DC when the rated load is reached)
5. Standard stroke: minimum value ≥ 20 mm, please refer to the table below for the maximum values of load and stroke.

Stroke: minimum value $\geq 20\text{mm}$, please refer to the table below for the maximum value of load and stroke

load (N)	Maximum stroke (mm)
2,000	50-200
1,200	201-300
1,000	301-400
800	401-600
600	601-900

Remark:

Lateral moment Y direction = $X \times 0.8$

Static lateral moment = dynamic $\times 2$

Dynamic lateral moment (Nm)-X direction

stroke	S+230	S+250
100-200	50	80
300-500	40	60
500-700	30	50
700-900	20	40

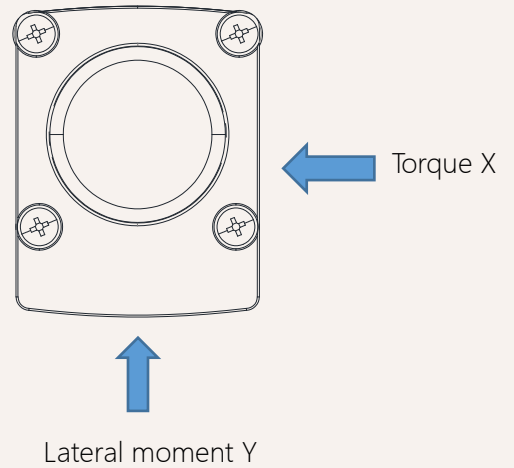

Stroke installation size reference chart

HTA23 Series	stroke ± 2 (mm)					Install ± 2 (mm)				
strokeMM	200	300	400	500	600	700	800	900	1000	
Install MM	265	315	365	415	465	515	565	615	665	
weight KG	1,2	1.4	1.6	1.8	2.1	2.3	2.5	2.7	3.2	

Actuator wiring diagram

No signal feedback wiring diagram

Code: N

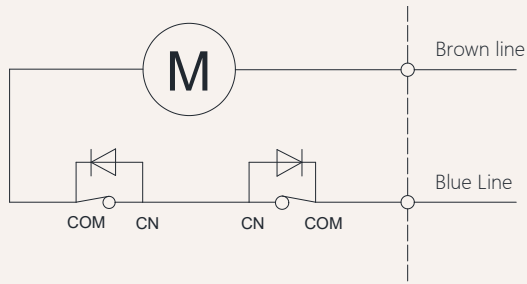

Wiring Instructions:

- 1] Brown lead: motor positive +
- 2] Blue lead: motor negative pole -
- 3] When the push rod is extended: the brown wire is positive +, the blue wire is negative -
- 4] When the push rod is retracted: the blue line is positive +, the brown line is negative -

Actuator wiring diagram Built-in control module

Built-in controller wiring diagram

Code: NY

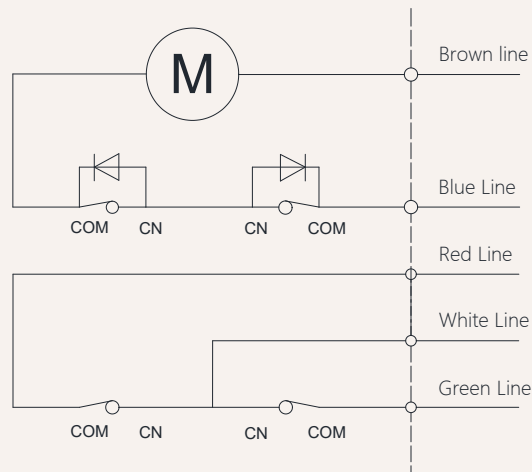

Wiring Instructions:

- 1] Brown lead: motor positive +
- 2] Blue lead: motor negative pole -
- 3] When the push rod is extended: white line + red line
- 4] When the push rod retracts: white line + green line
- 5] White line: control output common line.
- 6] White and red lines: stretch out,
- 7] White and green lines: retract,
- 8] Wireless remote control, use wired control simultaneously.

Other signal descriptions

Feedback signal	Description	Function
Active endpoint feedback signal	Voltage with this model	When the push rod reaches the end point, a signal will be fed back. This signal will always exist and will disappear during the operation of the push rod., When the push rod reaches the end point, it will feedback a signal. This signal always exists when the input power is not turned off. When the input power is turned off, the signal disappears. The signal will also disappear during the operation.
Passive endpoint feedback signal	No voltage	

Note: For other needs, please contact the GeMinG team

Signal feedback **Hall sensor**

Hall signal motor circuit diagram

Code: H

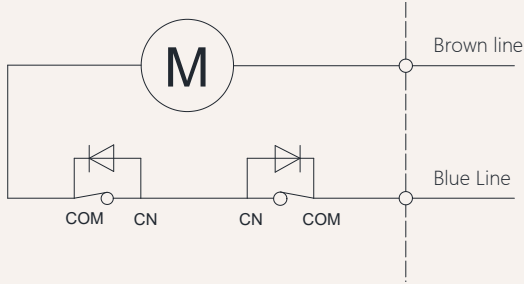

Hall signal output waveform diagram

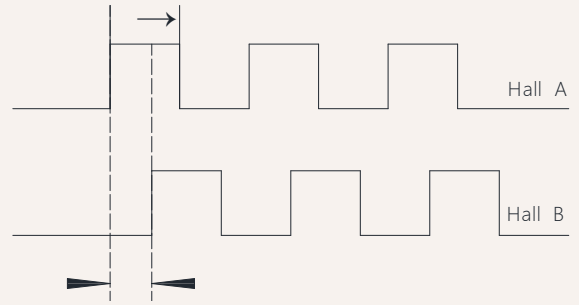

Schematic diagram of the internal circuit of the Hall signal

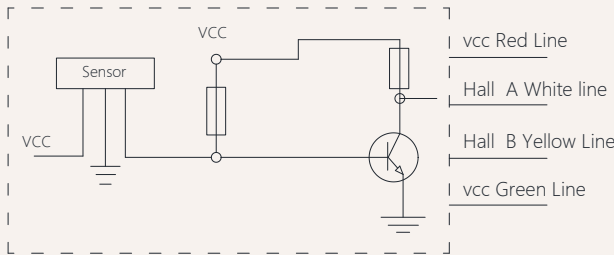

Wiring Instructions:

- 1] Brown lead: positive pole of motor +
- 2] Blue lead: negative pole of motor -
- 3] Red lead: VCC 5V voltage input +
- 4] Green lead: GND 5V voltage input -
- 5] White lead: Hall signal output A
- 6] Yellow lead: Hall signal output B

Notes:

- 1) Support dual-channel/single-channel Hall encoder
- 2) Current-consuming digital output
- 3) High-speed response frequency from: 0 KHz-100 KHz
- 4) Applicable temperature range:-40 °C~+125 °C

Characteristics	Symbol	Test conditions	MI	RE	M	Unit
Supply voltage	Vcc	----	3.5	---	24	V
Output saturation voltage	Vce/sat	Vcc=14V ; Ic=20mA	---	300	700	MV
Output leakage current	1 cex	Vce=14V ; Vcc=14V	---	<0	10	UA
Input voltage	1 ce	Vcc=20V ; Output open	---	1	10	M
Output fall time	R	Vcc=14V ; RL=820Ω ; CL=20pF	---	0.3	1.5	US

HTA23 Model Description Selection Code Table

HTA23 - 24 - B - 200 - 265 - O1 - O1 - 1 - 1 - T - A - N - 07
 ① ② ③ ④ ⑤ ⑥ ⑦ ⑧ ⑨ ⑩ ⑪ ⑫ ⑬

①	Product number	HTA23			
②	Voltage	12=12V DC, 24=24V DC, 36=36V DC, 48=48V DC			
③	Load(n)@Speed (mm/s)	See page 06			
④	Stroke(mm)	See page 06			
⑤	Installation size(mm)	Note: Before selecting a size, please refer to the valid data sheet! See page 05			
⑥	Upper type See page 13	O1 =Conventional ordinary type, hole diameter 8.5mm U1 = U-shaped, groove width 8mm, hole diameter 8.5mm M1 = Type M, M14 thread, depth 20 mm T1 = T-type, M14 thread, length 20mm L1 = L shape, width 8mm, aperture 8.5mm G1 = Spherical bearing, bore 10mm, model GS10	O2 = Conventional ordinary type, hole diameter 10.5mm U2 = U-shaped, groove width 8mm, hole diameter 10.5mm M2 = MType M, M16 thread, depth20 mm T2 = T-type, M16 thread, length 20mm L2 = L shape, width 8mm, aperture 10.5mm G2 = Spherical bearing, bore 12mm, modelGS12		
⑦	lower type See page 14	O1 =Conventional ordinary type, hole diameter 8.5mm U1 = U-shaped, groove width 8mm, hole diameter 8.5mm	O2 = Conventional ordinary type, hole diameter 10.5mm U2 = U-shaped, groove width 8mm, hole diameter 10.5mm		
⑧	Installation angle (counterclockwise)	0 =0°, Degree		9 =90°, Degree	
⑨	Please refer to the outlet type	1 = Dare wire 4 = Four-pin straight plug 7 = Waterproof plug		2 = 01 Straight plug 6 = Six-pin straight plug 0 = Customized	
⑩	Lead screw options	T = Trapezoidal screw (default preferred)		G= Ball screw rod	
⑪	Control method	A = No Control	NY =Integrated wired control NW=Integrated wireless control	NT = Synchronous control NC = CAN bus	D= Customized
⑫	Signal output options	N = No	H =Hall sensor	D = Potentiometer	W=passive signal U=active signal
⑬	Cable length	07 = 700mm 30 = 300mm	10 = 1000mm 40 = 4000mm	15 = 1500mm 70 = 7000mm	20= 2000mm 00 =Customized

Power cord type:

1 =Dare wire

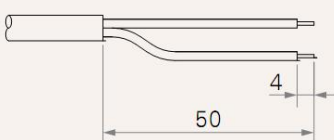

2 = 01 Straight plug

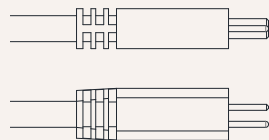

4 =Four-pin straight plug

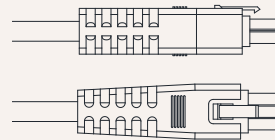

6 = Six-pin straight plug

